

MSD

VALVE SEAT GRINDING MACHINE

For in-situ grinding of valve seats on medium speed diesel engines.

- Range of operation 40 - 270 mm seat diameter
- Preset to any angle(s) from 0 - 60°
- Dowel locked to achieve correct angle
- Air driven
- Automatic outward feed mechanism

MSD VALVE SEAT GRINDING MACHINE

• MACHINE CAPACITY	40 - 270 mm SEAT DIAMETER
• AIR PRESSURE	0.6 - 0.9 MPa (6 - 9 bar OR 85 - 130 psi)
• AIR CONSUMPTION	700 l/min
• NOISE LEVEL	76 dB(A) / 75 dB(C)
• AIR HOSE CONNECTION	12.5 mm (1/2")
• GRINDING SPEED	3 mm/min (ALONG THE SEAT FACE)
• NORMAL GRINDING TIME	10 - 15 min PER SEAT
• WEIGHT	BASIC MACHINE 14 kgs SPINDLE 1 - 13 kgs
• MAX DIMENSIONS	H: MACHINE 371 mm + SPINDLE 185 - 1100 mm, W: 400 x 150 mm



Three advantages of air cooled grinding

1. Cooling

- cooled exhaust driving air flowing over valve seat during grinding helps eliminate heat induced micro-cracks.

2. Lubrication

- superior valve seat surface finish obtained thanks to lubricated driving air flowing over valve seat at grinding.

3. Dust free grinding

- lubricated exhaust air effectively binds all grinding dust and prevents any spreading, thereby securing non-polluted environment.

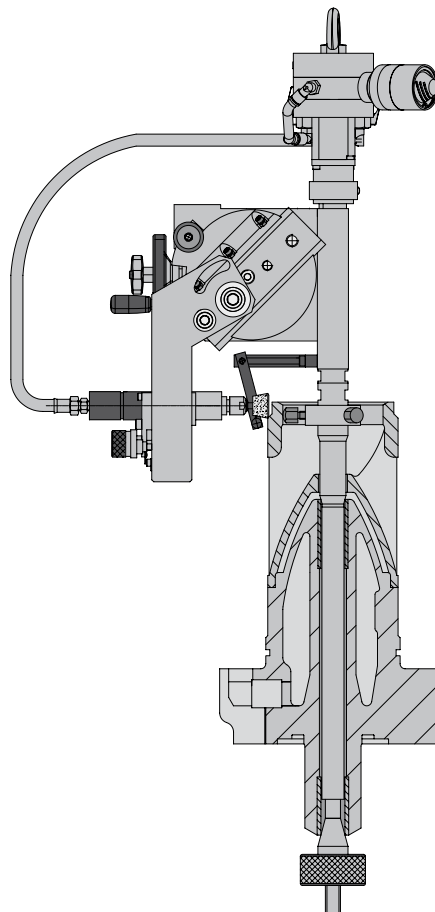

Unique feature

The MSD can also be used for other applications than grinding the valve seats. As an example; grinding the sealing surface between the valve cage and the cylinder cover.

Chris-Marine® Head Office and Subsidiaries

SWEDEN

Chris-Marine AB
Stenyxegatan 3
PO Box 9025
SE-200 39 Malmö
Tel: +46 - 40 671 2600
Fax: +46 - 40 671 2699
info@chris-marine.com

DENMARK

IOP Marine A/S
Engager 7
DK-2605 Brøndby
Tel: +45 - 4498 3833
Fax: +45 - 4498 1125
contact@iopmarine.dk

SINGAPORE

Chris-Marine (S) Pte. Ltd.
46 Lokyang Way, Jurong
Singapore 628646
Tel: +65 - 6268 8611
Fax: +65 - 6264 3932
chrism@chris-marine.com.sg

GREECE

CM Hellas Ltd.
16, Dodekanisou Str. (1st floor)
GR-18541 Piraeus
Tel: +30 - 210 4826 060
Fax: +30 - 210 4839 323
costas.sohoritis@chris-marine.com

P.R. OF CHINA

Chris-Marine Rep Office Shanghai
Rm. 6321, West Building,
Jin Jiang Hotel,
59 Mao Ming Road (S)
Shanghai 200020
Tel: +86 - 21 5465 3756
Fax: +86 - 21 6415 2081
lanny.chen@chris-marine.com

RUSSIA

Chris-Marine Rep Office
St. Petersburg
Office B44,
Malaya Konyushennaya Str. 1/3
St. Petersburg, 191186
Tel: +7 - 911 908 5482
Fax: +7 - 812 3292 597
andrey.egerev@chris-marine.com

INDIA

Chris-Marine Rep Office India
Plot No. 1/1, Vikas Apartment
Trimurthy Nagar, Ring Road
Nagpur-440022, Maharashtra
Tel: +91 - 712 224 2719
sunil.vaidya@chris-marine.com